

Session Initiation Protocol

Emulate Hundreds of Thousands of SIP calls over RTP

The Session Initiation Protocol (SIP) was originally submitted to the Internet Engineering Task Force (IETF) by researchers at MIT, Columbia University and Cal Tech in December 1996. The original draft document was submitted to the Multiparty Multimedia Session Control Working Group (MMUSIC WG) and SIP evolved through thirteen different drafts before being officially published as RFC 2543 in March 1999. After several years of active use, the SIP protocol was then updated in June 2002 as the current document, RFC 2543.

SIP is an application-level signaling protocol that provides a framework for the establishment, modification and termination of multimedia sessions. SIP is primarily used for internet telephony applications like voice over Internet Protocol (VoIP). SIP is able to support a unified addressing mechanism which allows SIP users to move network access points and still maintain connectivity and addressability. SIP is built heavily on the HTTP protocol, employing many of the existing headers and server-side response codes. Additionally, SIP utilizes the Session Description Protocol (SDP) for describing the multimedia content that is to be setup via SIP.

Figure 1

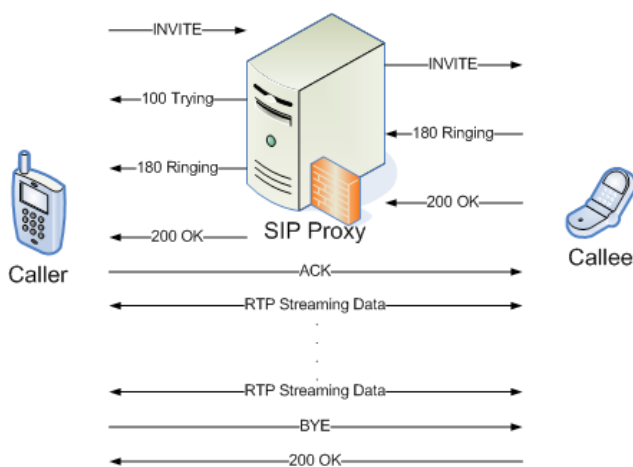

A typical SIP call establishment session.

BreakingPoint Testing Tools Emulate the SIP Protocol:

- One BreakingPoint Elite 3-slot chassis is able to generate hundreds of thousands of SIP calls
- Utilizing blended applications and security, users can fully test their network infrastructure to ensure SIP/RTP quality of service conditions are met under full network load
- Utilizing Application Manager allows users to create SIP flows to fully qualify SIP call establishment under both normal and abnormal protocol adherence.

SIP is not intended to be a stand-alone protocol to handle IP telephony applications. It was designed to work very closely with other IETF protocols including Real-time Transport Protocol (RTP) for multimedia stream transport, Real Time Streaming Protocol for multimedia stream control, Media Gateway Control Protocol (MGCP) for interfacing the Public Switched Telephone Network (PSTN), and SDP for describing multimedia sessions. While each of these additional protocols provides incremental services required for telephony, SIP is still an independent protocol that functions as such.

While most network application protocols have only a client and server, the SIP infrastructure may have multiple devices acting in concert to establish a SIP session, a key point in understanding the various requests available in the SIP protocol. When a caller wants to initiate a telephone call, that user sends an "INVITE" request, which contains the Uniform Resource Identifier (URI) of the destination, as well as other identifying information for the session. Once the callee sees the request, it will respond with the "RINGING" command, which is sent back to the caller. Assuming the callee chooses to answer the incoming call, a "200 OK" response is returned to the caller with an SDP description of the media channel to be used for the actual communication. The caller then sends an "ACK" command, also with an SDP description of the caller's side of the media channel. Once complete, the call data is communicated over the channel negotiated by the SDP messages. Once the call is complete, whichever side ends the call first sends a "BYE" command and the call is terminated.